

DS 80 series

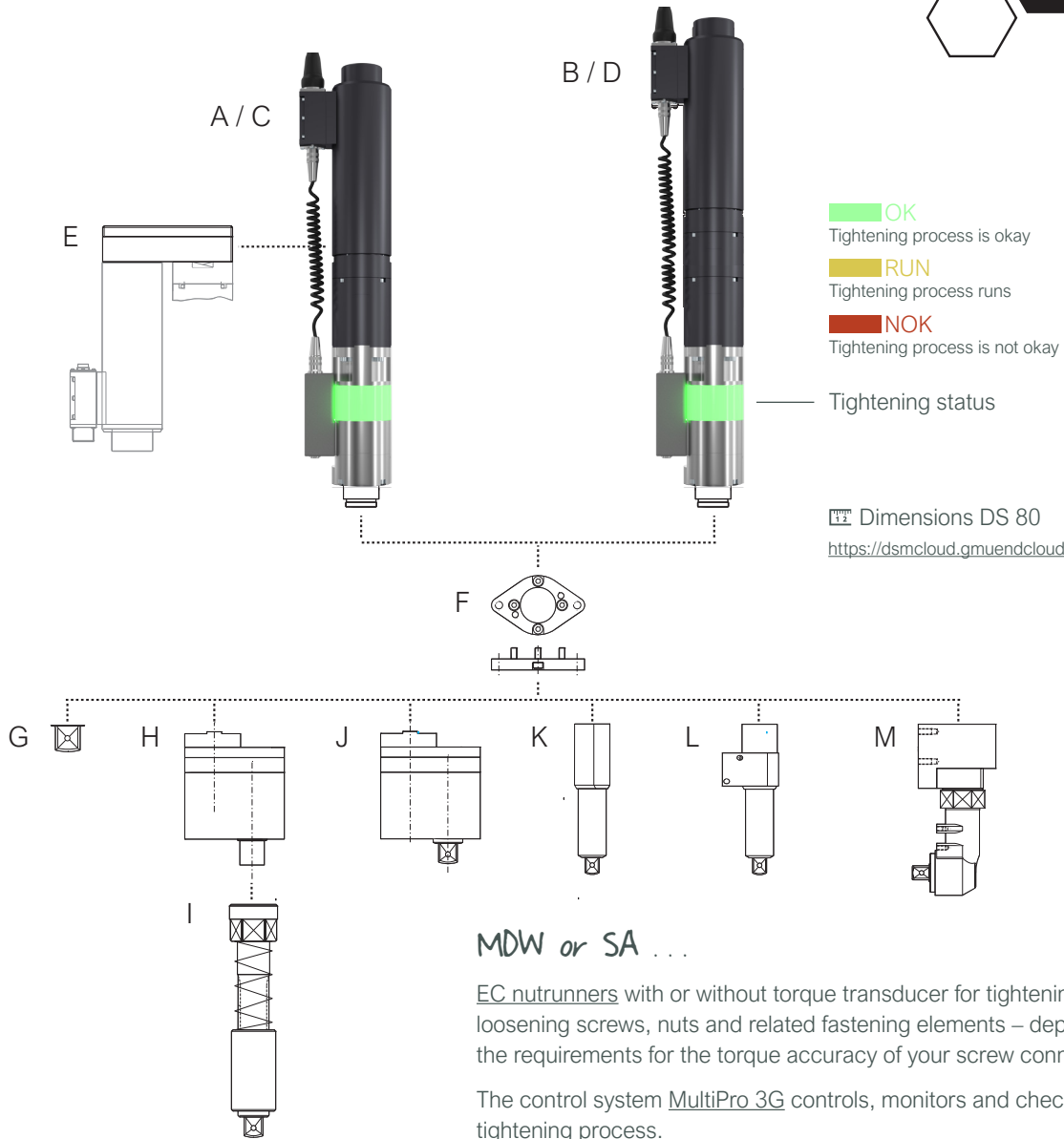
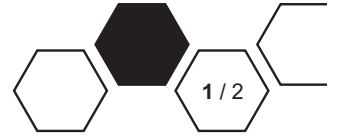

A DS 80 MDW with torque transducer

Type	Max. torque	Application area	Max. speed	Angle resolution	Article number
DS 80 / 220 MDW	220 Nm	44 - 220 Nm	320 rpm	0,1 °	DS-2800022
DS 80 / 300 MDW	300 Nm	60 - 300 Nm	320 rpm	0,1 °	DS-2800030

Torque accuracy 0,5 %, torque tolerance better 5 % according to ISO 5393; Execution „WA (Angle head)“: torque tolerance better 8% according to ISO 5393

B DS 80 MDW (Booster gear unit) with torque transducer

Type	Max. torque	Application area	Max. speed	Angle resolution	Article number
DS 80 / 420 MDW	420 Nm	84 - 420 Nm	160 rpm	0,1 °	DS-2800042
DS 80 / 500 MDW	500 Nm	100 - 500 Nm	160 rpm	0,1 °	DS-2800050
DS 80 / 600 MDW	600 Nm	120 - 600 Nm	160 rpm	0,1 °	DS-2800060

Torque accuracy 0,5 %, torque tolerance better 5 % according to ISO 5393

DS 80 series

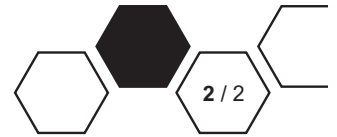

C DS 80 SA without torque transducer (current controlled)

Type	Max. torque	Application area	Max. speed	Angle resolution	Article number
DS 80 / 220 SA	220 Nm	44 - 220 Nm	320 rpm	1,2 °	DS-2801022
DS 80 / 300 SA	300 Nm	60 - 300 Nm	320 rpm	1,2 °	DS-2801030

Torque accuracy depends on the adjustment of the nutrunner

D DS 80 SA (Booster gear unit) without torque transducer (current controlled)

Type	Max. torque	Application area	Max. speed	Angle resolution	Article number
DS 80 / 420 SA	420 Nm	84 - 420 Nm	160 rpm	1,0 °	DS-2801042
DS 80 / 500 SA	500 Nm	100 - 500 Nm	160 rpm	1,0 °	DS-2801050
DS 80 / 600 SA	600 Nm	120 - 600 Nm	160 rpm	1,0 °	DS-2801060

Torque accuracy depends on the adjustment of the nutrunner

E Motor offset

Type	Article number
Motor offset V2	DS-2803005

F Mounting flange

Type	Article number
Mounting flange	DS-2803000

G Stump output

Type	Article number
Stump output ST, square drive 3/4"	DS-2803025

H Output offset (for spring output)

Type	Article number
Output offset V1 3K	DS-2803020

I Spring output (for output offset)

Type	Article number
Spring output 50 mm, 3K	DS-2803075

J Output offset with stump output

Type	Article number
Output offset V1 ST, square drive 1"	DS-2803015

K Spring output, square 3/4"

Type	Article number
Spring output 50 mm	DS-2803030
Spring output 100 mm	DS-2803040
Spring output 150 mm	DS-2803045

L Spring output with self start initiator, square 3/4"

Type	Article number
Spring output 50 mm with self start INI	DS-2803050
Spring output 100 mm with self start INI	DS-2803065
Spring output 150 mm with self start INI	DS-2803070

M Angle head 3/4" (max. 220 Nm)

Type	Article number
WA (3/4") Angle head equipped with fastening flange	DS-2803010

Nutrunner MDW / SA	Max. speed
DS 80 / 220 WA	200 rpm

And much more ...

individual technical solutions, handling systems, tool change boxes, crow foos as well as work stations.