

## Precise calibration of hand-held nutrunners and built-in nutrunners:

### Our mobile test bench offers maximum flexibility.

Our robust calibration test bench offers the perfect solution for the precise testing and calibration of nutrunners with a torque up to 500 Nm.

Thanks to its flexible modularity, the assembly of DS nutrunners as well as third-party tools is effortless. This test bench offers maximum versatility with specially adapted mounting plates for each size and thumb nuts for secure fastening.

Tool clamps ensure additional fixation of the nutrunner. The tightening simulator is attached to the base plate. The height can be easily adjusted with the handwheel, depending on the configuration of the simulator and the installation size of the reference measuring sensor.

Our mobile calibration test bench can be easily positioned on the floor, on a workbench, or on a transport trolley without the need for time-consuming assembly. The foldable stand ensures additional stability and enables safe use.

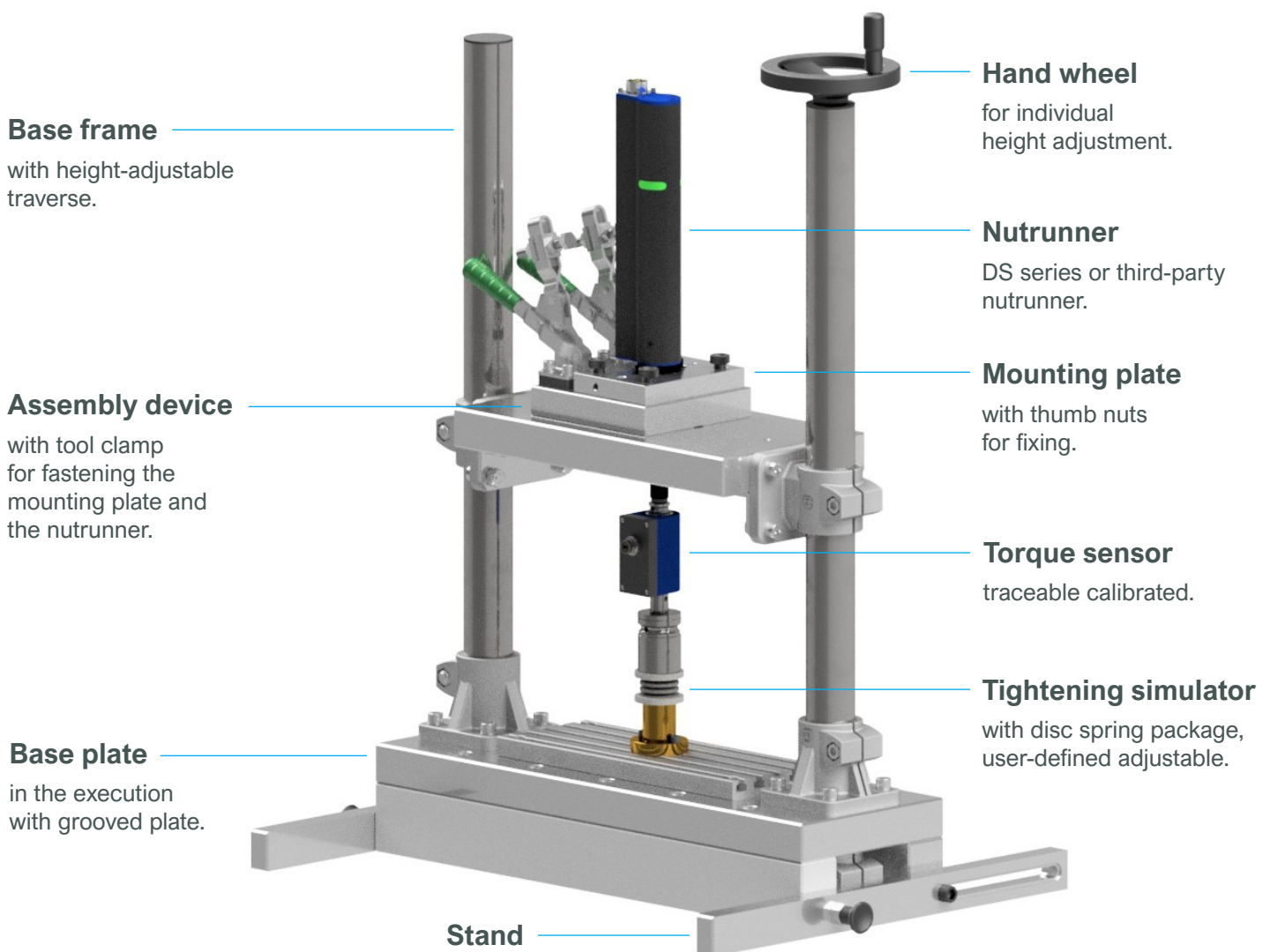

### Design of the test bench and available equipment variants

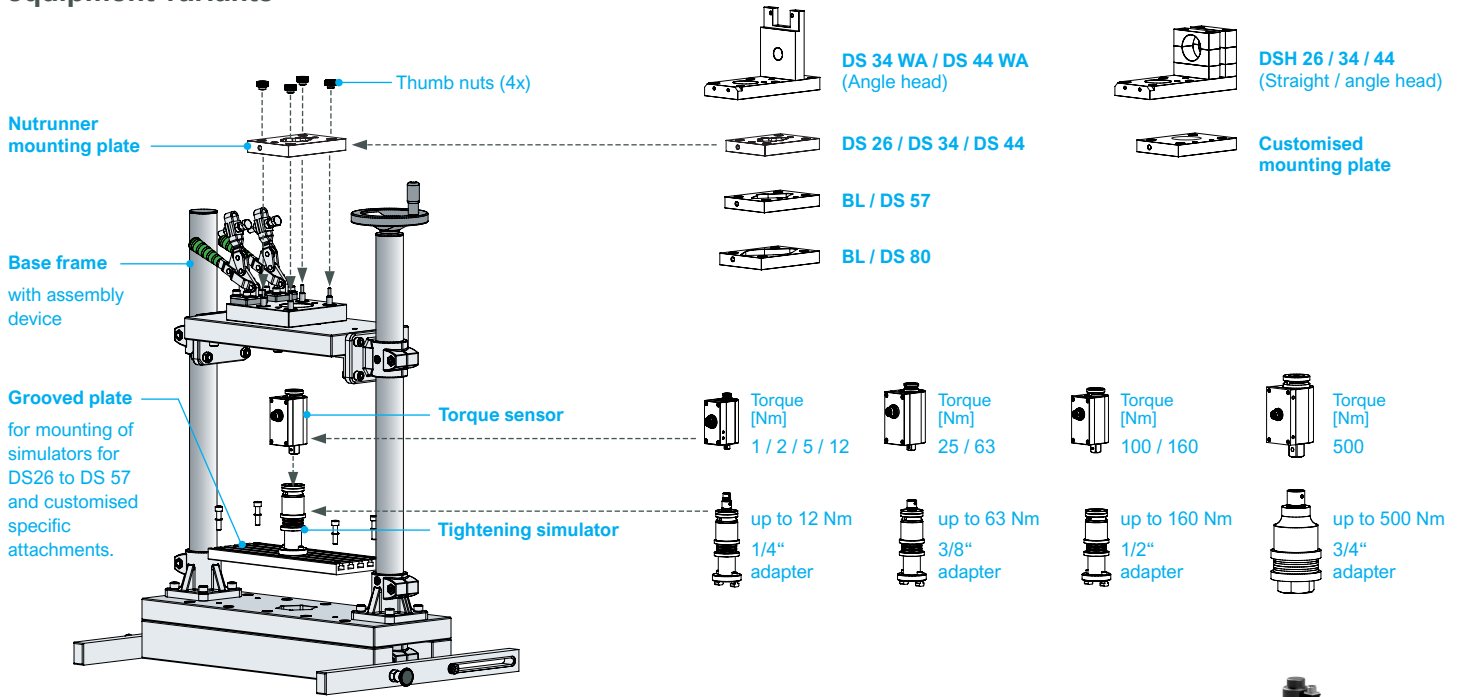

**Transport position**  
Release the locking bolts to lift the stands for space-saving transport.

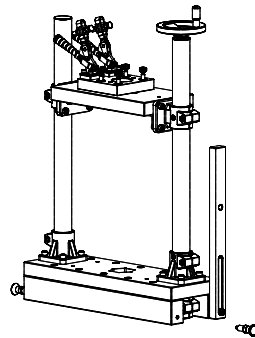

Exampel with nutrunner DS 44



Example with nutrunner DS 80



### Dimensions and weight

